

1 Things Worth Knowing about Electric Machines

1.1 Electric Machines Generally

Extensive physical knowledge of magnetism, current bearing, stationary and moving conductors in the magnetic field is necessary in order to understand electric machines.

Generators and motors are combined under the term „rotating electric machines“. Electric machines make use of the magnetic effect. Generators convert supplied mechanical energy into electrical energy, motors on the other hand convert supplied electrical energy into mechanical energy.

Electric machines are classified according to their function: e. g. DC machines, synchronous machines, induction machines etc. The operating mode of the machine is reversible; the expression „electric machines“ is therefore a generic term. Whether it is a motor or a generator is determined when it is used.

Transformers are „stationary“ electric machines and convert high voltages or currents into lower voltages or currents and vice versa.

1.2 Standard Designs

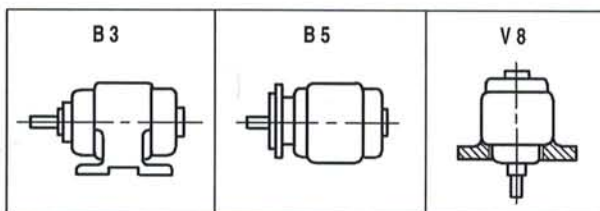

Fig. 1.2.1 Examples of designs

The designs of electric machines are standard. A letter followed by a number, e. g. B 3 is used as an abbreviation. This example describes a motor with a shaft end and a base fastening (see Fig. 1.2.1). The abbreviation provides information on the bearing, fastening, setting up

and shaft. The design guarantees identical dimensions even when manufactured by different companies.

Detailed information about the design is available from the latest tables or the DIN and IEC regulations respectively.

1.3 The Structure

The stationary part of a rotating electrical machine is known as the **stator** and the rotating part as the **rotor**.

In the structure of an electric machine, a distinction is made between parts which conduct the electrical current or the magnetic flow and construction parts.

1.4 Cooling and Ventilation

When operating rotating electric machines, losses occur which cause heating. This so called heat loss must be limited or emitted to the environment until a thermal balance is achieved. Too much heat may destroy the insulation of the windings and make the machine useless.

Electric machines usually have self-cooling, whereby a ventilating fan connected to the rotor feeds the cooling air past the parts of the machine to be cooled. The housing surface of the machine also emits heat to the environment. The more effective the self-cooling, the smaller a motor may be constructed with the same power.

In addition to the self-cooling, machines with external cooling exist. The cooling air is generated here by a ventilator with its own drive or a coolant is fed through parts of the machine.

1.5 Insulating Material Classes

The windings of standard electric machines are made of enamelled wires. However, often a machine needs to be operated at higher ambient temperatures. Therefore there are different insulating material classes with maximum permissible permanent temperatures (see Table 1.5.1).

Insulating material class	Maximum permissible permanent temperature
Y	90 °C
E	120 °C
F	155 °C
H	180 °C

Table 1.5.1

1.6 Motors and Their Operating Behaviour

The operating behaviour of a motor is determined by its torque/speed behaviour. The no-load speed, depending on the type of the motor, is higher than at rated load. The change in speed (rated slip) is specified in % of the rated speed.

The operating behaviour of electric machines is divided into four groups:

• Synchronous behaviour

The change in speed is zero (synchronous motor), i. e. the speed does not drop under load.

• Shunt behaviour

The change in speed is < 10 % (shunt-wound DC motor, single-phase and three-phase induction motor, shunt-wound three-phase motor).

• Compound behaviour

The change in speed is 10 ... 25 % (three-phase slip-ring motor with fixed slip step, plain compound DC motor).

• Series behaviour

The change in speed is > 25 % (series-wound DC motor and single-phase series-wound motor).

1.7 The Direction of Rotation

The direction of rotation of the rotor of an electric machine is always determined by looking at the end of the shaft on the drive side. In right hand rotation the rotor rotates clockwise, in left hand rotation the rotor rotates anti-clockwise (see Fig. 1.7.1). Every motor has an A and a B side.

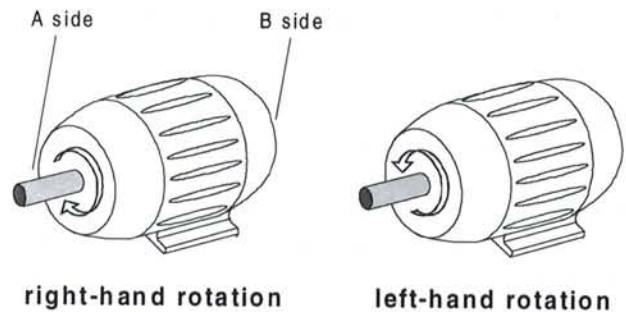

Fig. 1.7.1 Determining the direction of rotation

A side:

- drive shaft
- with two different shaft ends:
large shaft diameter
- with two identical shaft ends:
e. g. opposite the sliprings or the commutator

B side:

- ventilator:
(in special machines the ventilator may also be on the A side)
- small shaft diameter
- slipring side or commutator side (ventilator)

1.8 Operating Mode as a Criterion for Selecting a Motor

The operating mode is very important when selecting an electric motor. For example, a motor heats up on a temporary load less than under permanent load and a smaller one can therefore be selected.

A distinction is made between the operation modes S1 ... S9:

- In **permanent mode S1** (see Fig. 1.8.1) the operating duration at rated load is so long that the steady state temperature is reached. These motors are suitable for permanent operation, i. e. they may be operated „permanently“ with their rated load.
- In **temporary mode S2** (see Fig. 1.8.2) the operating duration in comparison with the following pause is so short that the steady state temperature is not reached. The motor cools down to the output temperature in the subsequent longer pause.
- In **intermittent mode S3, S4, S5** (see Fig. 1.8.3), the pauses are short. They are not sufficient to cool down the motor to room temperature.
 - **S3** exists when the starting current is negligible for heating up the motor.
 - **S4** exists when the starting current is significant for heating up the motor.
 - **S5** exists when the motor is heated additionally by the braking current.
- In **continuous operation with intermittent load S6** (see Fig. 1.8.4) the no-load pauses are not sufficient for cooling down the motor.
- There are **practically no pauses in intermittent operation with starting and braking S7**. The motor is permanently under voltage. A certain number of cycles per hour may not be exceeded.
- In **continuous operation with pole reversal S8** the motor runs permanently under load but with frequently changing speed.
- In **continuous operation with aperiodic load and speed variation S9**, load peaks may occur which are above the rated power.

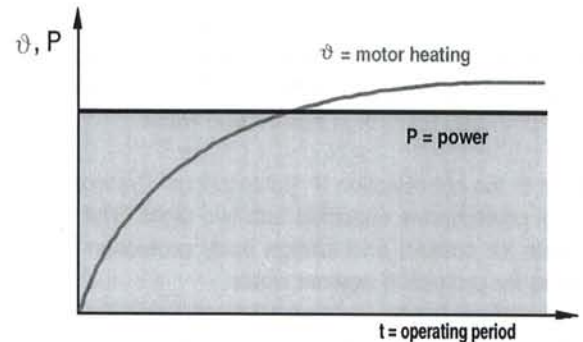

Fig. 1.8.1 Permanent mode S1

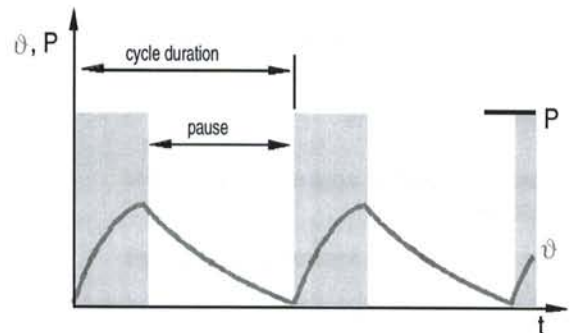

Fig. 1.8.2 Temporary mode S2

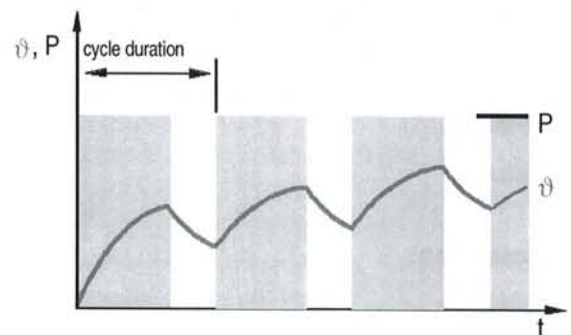

Fig. 1.8.3 Intermittent mode S3

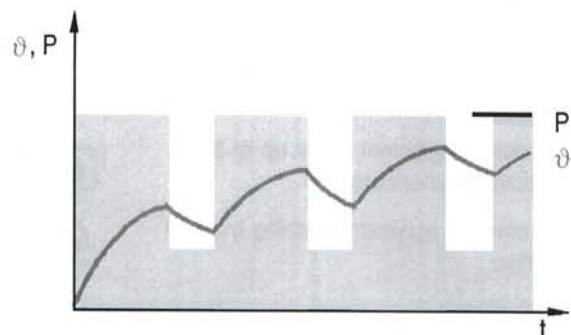

Fig. 1.8.4 Continuous operation S6



1.9 The Type of Protection as a Measure of Safety

The type of protection indicates that important construction regulations have been observed which protect persons from touching live parts (active parts) and the motor against penetration by foreign bodies and water.



In addition to the abbreviation **IP** (International Protection) the type of protection is specified with two digits. The first digit stands for contact and foreign body protection and the second for protection against water.



The various types of protection according to EN 60 259 are listed below with the corresponding VDE symbols:

Contact and foreign body protection:

IP 0X	no contact protection	
IP 1X	contact protection against foreign bodies > 50 mm ϕ	
IP 2X	contact protection against foreign bodies > 12 mm ϕ	
IP 3X	contact protection against foreign bodies > 2.5 mm ϕ	
IP 4X	contact protection against foreign bodies and tools > 1 mm ϕ	
IP 5X	protection against dust accumulation on the inside	
IP 6X	dustproof	

Water protection:

IP X0	no water protection	
IP X1	protection against water drops, vertical drops	
IP X2	protection against water drops, drops falling at an angle up to 15° from the vertical	
IP X3	protection against spray up to 30° above the horizontal	
IP X4	protection against splashing from all sides	

IP X5	protection against water jets	
IP X6	protection against flooding	
IP X7	protection when immersed	
IP X8	protection when submerged	

Electric machines from hps specify IP 20 or IP 54 on the rating plate. This is explained in detail below:

IP 20	Contact protection against foreign bodies > 12 mm ϕ , no water protection	
IP 54	Protection against accumulation of dust inside, splash protection from all sides	

1.10 The Rating Plate as User Information

All the important parameters for an electric machine are specified on the rating plate. These data are necessary for assessment and selection of the machine.

Fig. 1.10.1 shows a rating plate with all possible specifications. The boxes are numbered from 1 ... 23. Their order is not fixed. All the boxes are explained in the table 1.10.1.

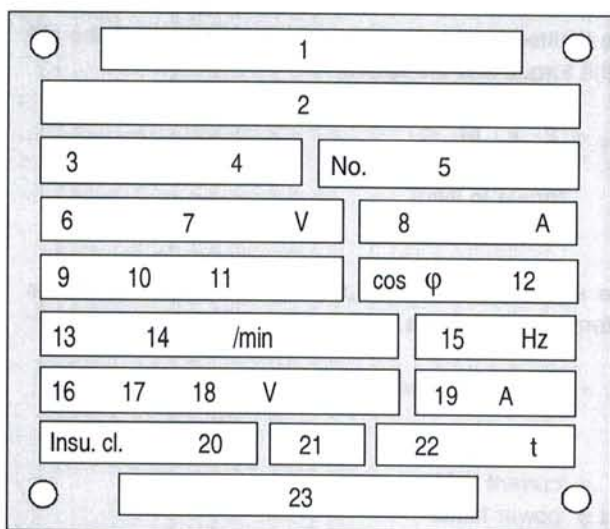

Fig. 1.10.1 Rating plate

Box no.	Parameters
1	name of the manufacturer
2	type designation
3	type of current
4	function
5	manufacture number
6	switching type of the stator winding
7	rated voltage
8	rated current
9	rated power
10	unit Watt [W or kW]
11	operation mode
12	rated power factor
13	direction of rotation
14	rated speed
15	rated frequency
16	specification for excitation
17	switching type of the rotor winding
18	rated value for the exciting voltage
19	rated value for the exciting current
20	insulating material class
21	types of protection
22	weight in t (only for large machines)
23	additional notes

Table 1.10.1 Possible specifications on the rating plate

1.11 Connection Designations

Connection designations are standardized and consist of capital letters and digits. The digits indicate start (1) and end (2) of a winding. The taps are identified by the digits 3 or 4.

The tables 1.11.1 and 1.11.2 list the connection designations for DC and AC machines used in the manual:

DC machines	
armature	A1 - A2
commutating pole winding	B1 - B2
compensation winding	C1 - C2
series excitation	D1 - D2
shunt excitation	E1 - E2
external excitation	F1 - F2

Table 1.11.1

AC machines	
stator (star circuit)	U1 - U2, V1 - V2, W1 - W2
stator (delta circuit)	U, V, W
star point	N
rotor winding	K, L, M
protective earth	PE

Table 1.11.2

1.12 Efficiency and Losses

The **efficiency** η is the ratio of the emitted to the supplied power.

$$\eta = \frac{P_{out}}{P_{in}}$$

Losses occur during operation of every motor so that the emitted active power P_{out} is always smaller than the supplied active power P_{in} .

In rotating motors, friction losses occur in the bearings, heat losses in the windings and magnetic losses due to eddy currents in stator and rotor which are also known as iron losses.

The emitted mechanical power is determined with the aid of the torque and the speed:

$$P_{out} = 2 \cdot \pi \cdot M \cdot n$$

M torque in [Nm]
 n speed in [s^{-1}]

The supplied power of a „three-phase current motor“ is determined as follows:

$$P_{in} = \sqrt{3} \cdot U \cdot I \cdot \cos \varphi$$

U electric voltage in [V]
 I current in [A]
 $\cos \varphi$ power factor

P_{in} must be measured in the same passage as P_{out} . Only then the „correct“ value can be determined for the efficiency. The efficiency has its maximum value in rated operation.